



**stratus**  
thermal lantern roof

**Tools required:**

- Tape measure
- Drill and bits as required
- Rubber or plastic mallet
- Screwdriver and 8mm nut runner or socket
- Sealant gun and sealant !
- Hacksaw

# Installation Guide

version 9

! Please ensure that all Sealant used is compatible with the type of glass being fitted in the installation.



Watch Stratus  
Installation Video

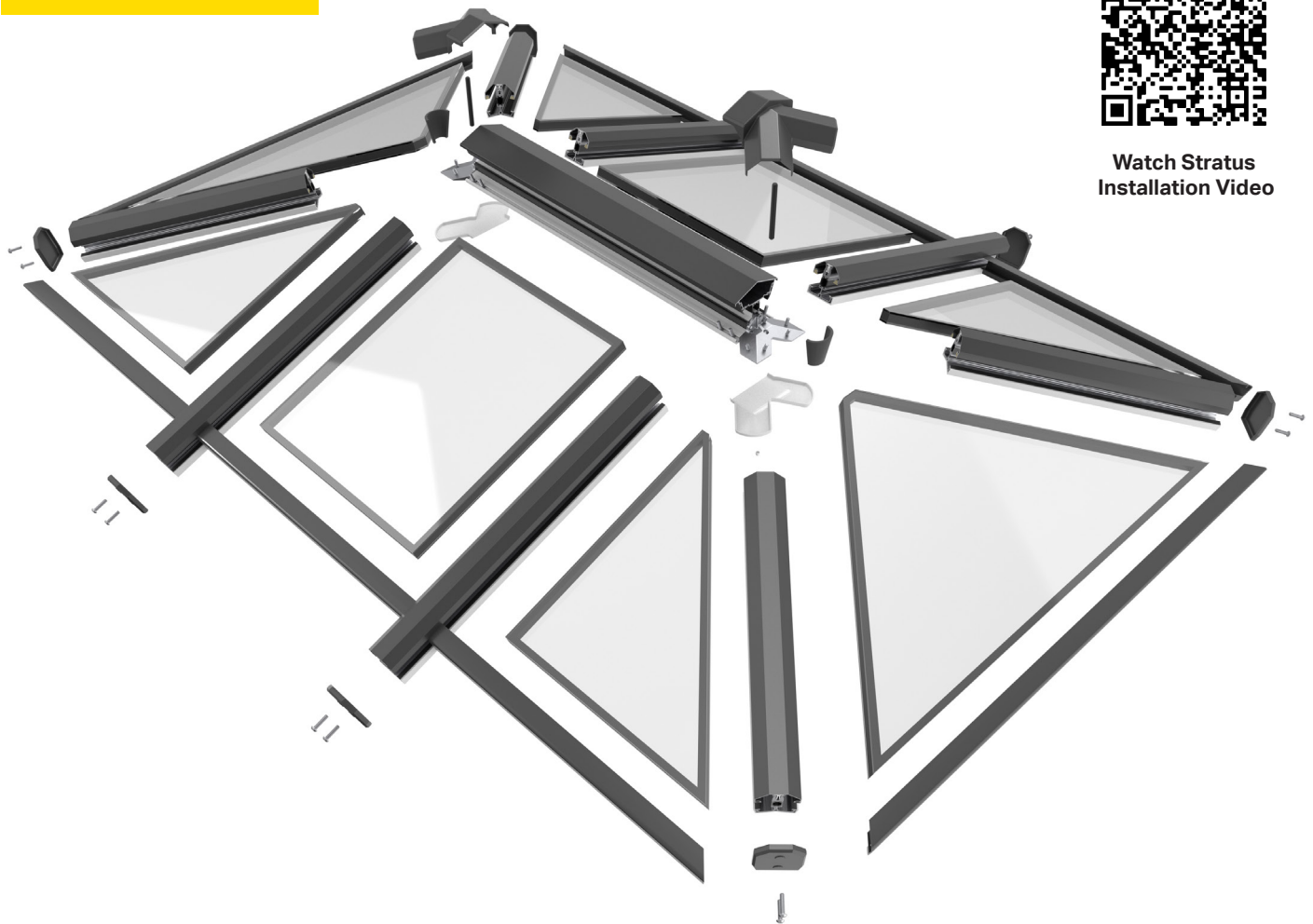

4 way design

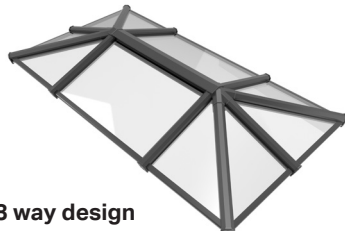

3 way design

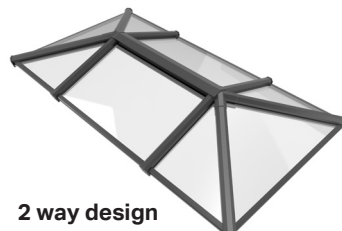

2 way design

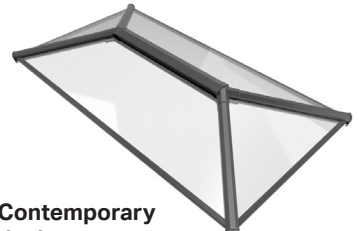

Contemporary  
design

Your easy to follow guide to Stratus - the innovative fully thermally broken lantern roof

1

Ensure supporting construction is square by checking diagonals. Measurements to be taken to outside corners of supports. The customer must ensure that the kerb and surrounding roof can adequately resist the horizontal spread of the lantern.

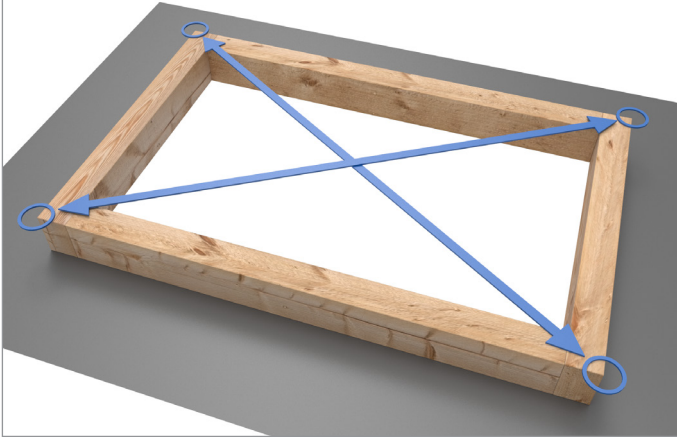

2

Apply a generous bead of suitable sealant around the full perimeter of the supporting structure. Positioned as shown.

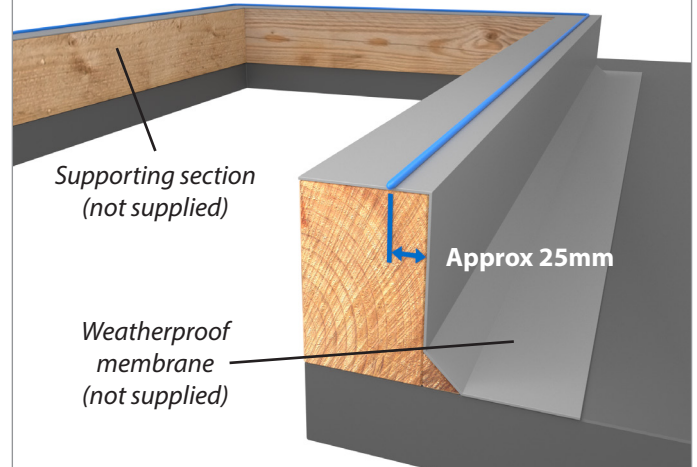

3

Secure eaves beam into supporting upstand using appropriate fixings. Fixings to be positioned as shown in diagrams 3 and 4.

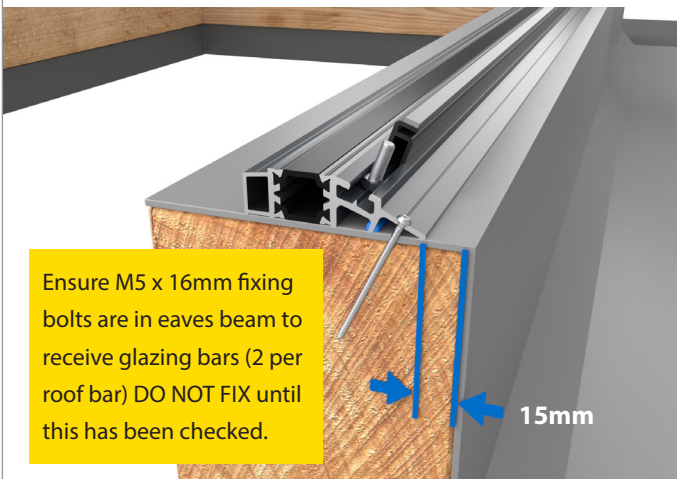

4

Sealant to be applied between intersection of eaves beams at corner joint using appropriate product.

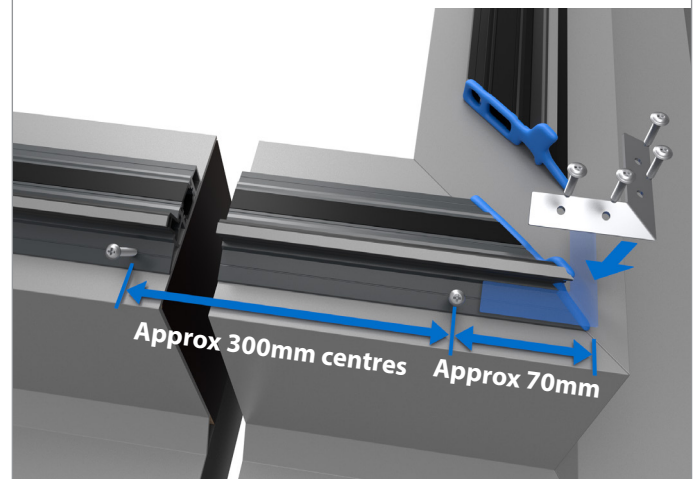

5

Fit glazing bars to eaves beam and ridge section in sequence shown. DO NOT fully tighten fixing bolts to allow fitting of hip rafters.

Secure glazing bars and Georgian hips to eaves beam and ridge using M5 x 16mm bolts (supplied in the eaves beam). Fully tighten fixing bolts to secure.

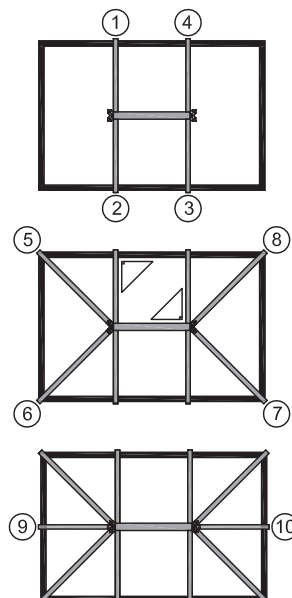

Fit Georgian hip bars to eaves beam and ridge section in sequence shown. When all sections are in correct position check they are square to eaves beam and ridge and tighten to fix in position.

Fit central glazing bars to eaves beam and ridge section in sequence as per diagram if required.

6

Secure all rafters and hips to eaves beam using M5 x 16mm bolts.



7

Rafters will need fitting with a gentle rotation to fit over bolts when fixing to ridge. Take care when positioning, not to scratch powder coated surface of ridge.

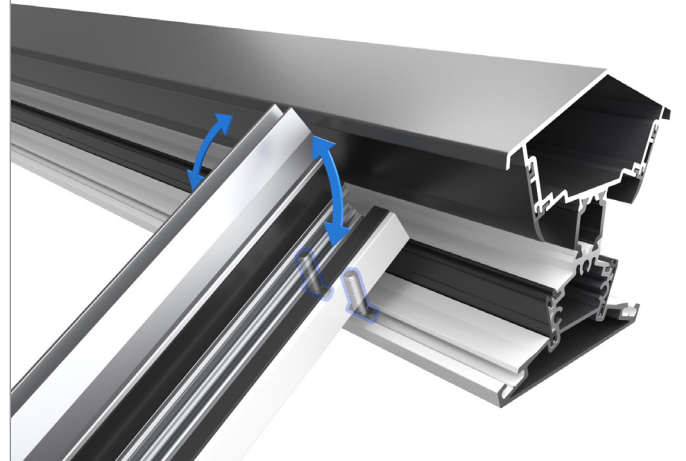

8

Fix hips to radius end using M5 x 16mm bolts.

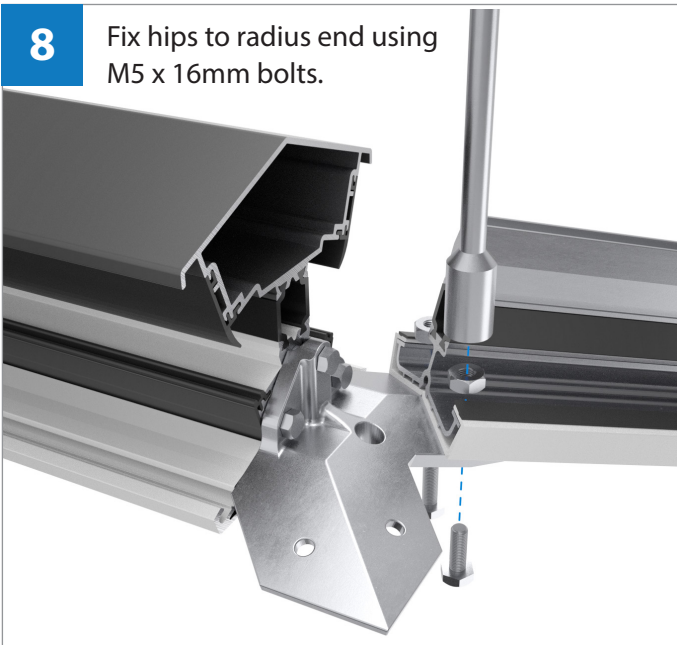

9

Ensure that support infill is fitted between all glazing bars and Georgian hips. Fold back approx. 25mm of protective tape from support infill to allow it to be removed once glazing unit is in correct position.

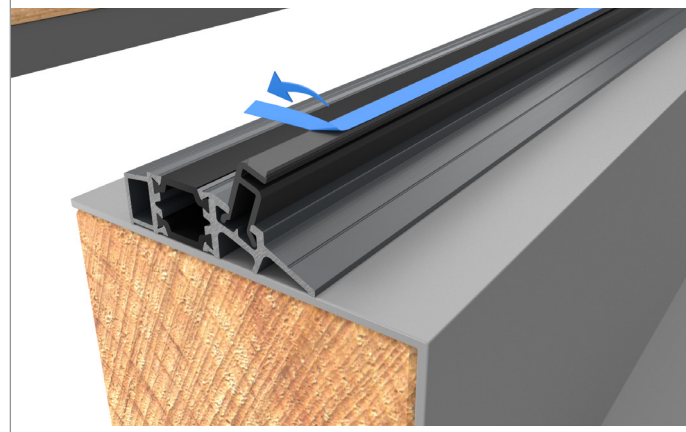

10

Use this sequence to glaze the units in their correct locations to balance weight evenly.

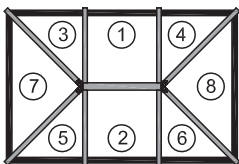

2 way design

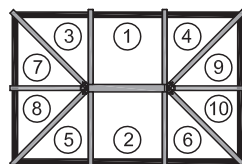

3 way design

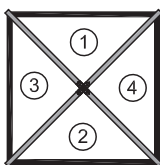

4 way design

11

When attaching the glazing closers on a contemporary design roof, it is advisable to seal the closer to the DGU to prevent the possibility of any central sagging to the end closer.

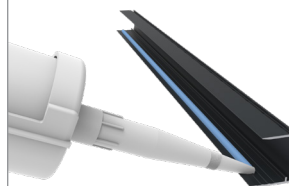

Apply a thin bead of sealant to the top wing of the glazing closer and attach. Secure with suitable masking tape and remove when cured.



**12** Top caps are located into their respectively numbered glazing bar. Tap down till fully located using a plastic or rubber mallet on a section of timber to avoid damage to capping.



**14** Now fit the radius end foam infills. They fit back to back as shown below.

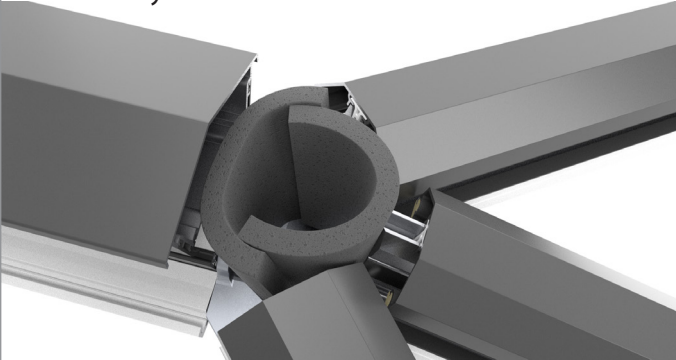

**16** Insert ridge holding bolt into receiving boss on underside of top cap casting.

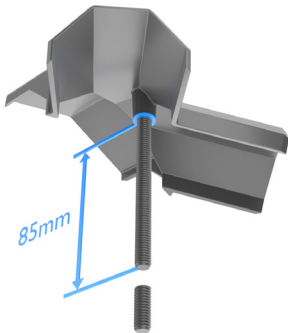

Turn clockwise and lock in position. When fully tightened cut down to 85mm from end of threaded rod to edge of aluminium boss.

**13** Seal glazing bar and top cap to ridge section using appropriate sealant.

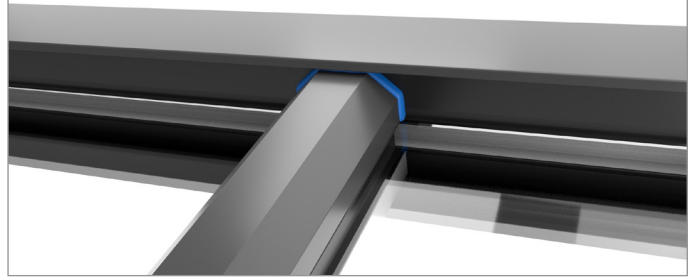

**15** Sealant to be applied as indicated on this image to seal glazing bars and hip rafters up to radius end foam infills.

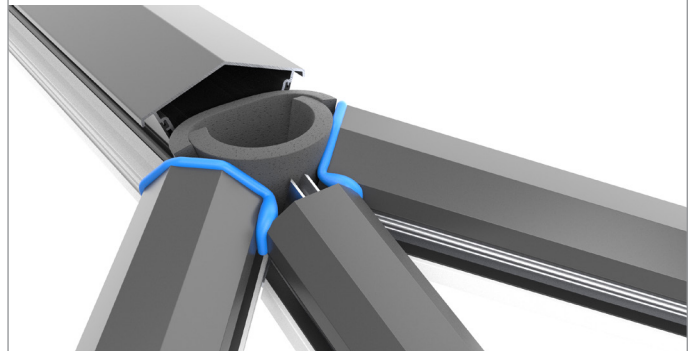

**17** Sealant to be applied to the underside of the top aluminium boss as indicated on this image.

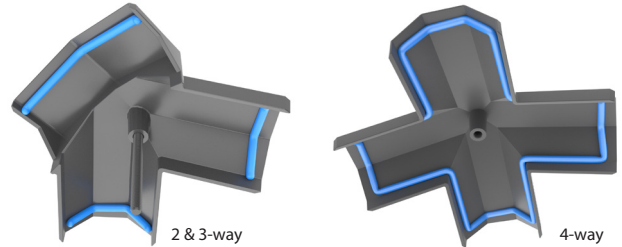

**16** Insert ridge holding bolt into receiving boss on underside of top cap casting.

**19** Secure end caps on all glazing bars and Georgian hip rafters using 4.2 x 25mm self-tapping screws (as supplied).

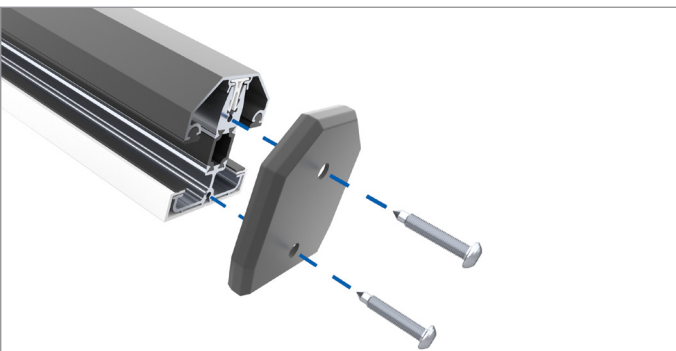

**18** Fit top caps. Ensure gap between hip and ridge is sealed when no rafter is fitted.

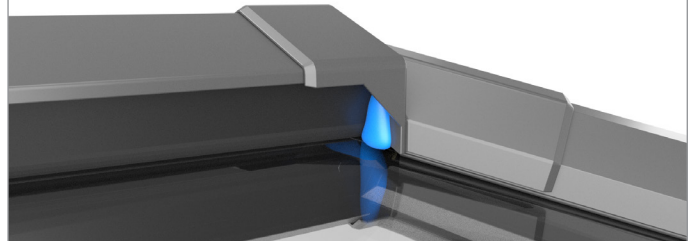

**20** Drill 8mm diameter hole in bottom cap for nylon fixing bolt to pass through. Position indicated on inside of cover. Secure using M8 nylon nut.

